

# TRIUMPH-1M Plus

## User Manual



Version 6

July 2023

## Table of Contents

|  |    |
|--|----|
| 1. TRIUMPH-1M Plus Overview .....              | 4  |
| 1.1. Shipping Contents .....                   | 4  |
| 1.2. Appearance .....                          | 4  |
| 1.3. Ports and Buttons .....                   | 6  |
| 1.4. Wireless Interfaces .....                 | 6  |
| 1.5. LED's .....                               | 7  |
| 1.6. Options Authorization File (OAF) .....    | 8  |
| 1.7. Firmware Update .....                     | 9  |
| 1.8. Mounting .....                            | 9  |
| 2. Port Connections.....                       | 10 |
| 2.1. USB .....                                 | 10 |
| 2.2. Bluetooth .....                           | 10 |
| 2.3. Wi-Fi .....                               | 10 |
| 2.4. Power Management .....                    | 11 |
| 2.5. External UHF Radio Connection .....       | 12 |
| 3. Software Interfaces .....                   | 13 |
| 3.1. NetView&Modem .....                       | 13 |
| 3.2. Javad Mobile Tools (JMT) .....            | 13 |
| 3.3. Field Survey .....                        | 14 |
| 4. RTK Configuration .....                     | 15 |
| 4.1. RTK Setup for both Base and Rover .....   | 15 |
| 5. Setup and Survey.....                       | 17 |
| 5.1. Measure Antenna Position .....            | 17 |
| 5.2. Collect Data .....                        | 18 |
| 5.3. Static Survey for Base Stations .....     | 19 |
| 5.4. Kinematic Survey for Rover Stations ..... | 20 |
| 5.5. RTK .....                                 | 20 |
| 5.6. File Maintenance.....                     | 21 |
| 6. Mechanical Properties .....                 | 22 |
| 7. Troubleshooting .....                       | 23 |
| 7.1. Check this First .....                    | 23 |
| 7.2. FAQ .....                                 | 24 |
| 8. User Information .....                      | 26 |
| 8.1. Safety Information .....                  | 26 |
| 8.2. Usage and Safety .....                    | 26 |

---

|      |                                |    |
|------|--------------------------------|----|
| 8.3. | Radio Frequency Exposure ..... | 26 |
| 8.4. | Warranty .....                 | 26 |
| 8.5. | Technical Support .....        | 26 |

## 1. TRIUMPH-1M Plus Overview

Ensure that all of the following items have been included with your Triumph-1M Plus device shipping pack. If anything is missing, contact your dealer as soon as possible.

Check all documentation. Read the documentation that came with the equipment and keep it for future reference. Check all documentation. Read the documentation that came with the receiver and keep it for future reference.

### 1.1. Shipping Contents

The TRIUMPH-1M Plus is shipped with the items shown in the table below.

| Description                           | Part Number  |
|---------------------------------------|--------------|
| Triumph-1M Plus GNSS Receiver         | 01-630100-21 |
| Triumph-1M Plus Pole Adaptor          | 10-590293-01 |
| Extension Cable SAE/SAE (1.8m)        | 14-578102-01 |
| Power Cable, 1-3.5 plug / SAE (0.33m) | 14-578125-01 |
| AC Power Cable, C13/C14, 6 ft.        | 14-578153-01 |
| USB Cable, A / micro-B, 1m            | 14-578156-01 |
| JAVAD Transport case                  | 20-720300-01 |
| Power Supply/Charger 24VDC 90W        | 22-570106-20 |
| AC Power Adapter*                     | 23-590029-0X |

\*AC Power adapter depends on the AC socket type per country

### 1.2. Appearance



1: Front View

Figure



Figure 2: Back View



Figure 3: Bottom View

### 1.3. Ports and Buttons

The device has just two physical interfaces (ports) on the back panel of the unit. Both interfaces are closed with protective rubber cover. It is strongly recommended to keep them closed while you are not using it.

#### 1.3.1. Ports:

- USB type Micro B (High Speed).
- Power port type 1-3.5 DC power input.

Note: Please use only the power charger system packed with the device. Using any other type of power charger can cause damage.

#### 1.3.2. Buttons

- Power Button (PWR).
- Record Button (FN).

Note: REC button is one programmable button. In further instructions it is called the FN button (“Function”).

### 1.4. Wireless Interfaces

There are two antennas (Bluetooth and Wi-Fi) placed under the housing cover. In addition, the cellular and UHF antennas are located within the provided Triumph-1M Plus Pole Adaptor (P/N: 10-590293-01) and are shown below.



Figure 4: Wireless Interfaces

## 1.5. LED's

The TRIUMPH-1M Plus has 6 RGB LEDs on the front panel.

Power (PWR) LED (no external charge):

- Green – Battery power level >30%.
- Yellow – Battery power level from 15% to 30%.
- Red – Battery power level <15%.
- Blue – Instantly flashes while pressing PWR button.
- No Light – Device is off.

Power (PWR) LED (with external charge):

- Green – Device is fully charged.
- Yellow – Device is charging.
- Red – Failed charging.

Bluetooth (BT) LED:

- Blue – Bluetooth is on, connection established (for multiple SPP connection Blue LED is flashing every 15 sec.).
- Red – Bluetooth is on, no connection.
- No Light – Bluetooth is off.

Wi-Fi (WLAN) LED:

- Green – Wi-Fi is on, connection established.
- Red – Wi-Fi is on, no connection.
- No Light – Wi-Fi is off.

Satellite (SAT) LED:

- Green – More than 8 usable satellites.
- Yellow – 5 – 8 usable satellites.
- Red – 1 – 5 usable satellites.
- No light – No satellites tracked.

Position (POS) LED:

- Green – Position type matches requested type.
- Yellow – Position type is less than requested type (e.g., current position computed is standalone when RTK fixed positioning mode is configured).
- Red (flashing) – No position.
- Red/Yellow/Green flashing one-by-one – SV tracking option is not active.

Record (REC) LED:

- Green – Log file is being recorded.
- No Light – No file is being recorded by now.

The usual stable tracking/positioning indicator would be shown by a constant green light for <SAT> LED and a flashing green light for <POS> LED.

If no satellites are being tracked (impossible to compute position), the <SAT> LED will be off and the <POS> LED with flash red.

## 1.6. Options Authorization File (OAF)

JAVAD GNSS issues an Option Authorization File (OAF) to enable specific purchased options. An Option Authorization File allows customers to customize and configure the Triumph-1M Plus receiver according to their needs, thus only purchasing those options needed.

Typically, all Triumph-1M Plus receivers are shipped with a temporary OAF that allows the receiver to be used for a predetermined period. When the receiver is purchased, a new OAF activates purchased options permanently. Receiver options remain intact when clearing the NVRAM or resetting the receiver.

For a complete list of options and their details, visit the JAVAD GNSS website.

You can check the status of your receiver’s options and load any new OAFs via NetView&Modem software. Connect your receiver and computer, launch NetView&Modem application, and establish connection between NetView and receiver. For more details, see the NetView&Modem user manual.

In “Options” tab, the list of options available and their status are shown:

- Option name / Description – A name/description of the option.
- Current – Shows if the option is in force at the present or not.
- Purchased – If the option is purchased or not.
- Leased – If the option is leased or not.
- Date – The date the leased option will be disabled, if applicable.

| Option           | Current | Purchased | Leased | Date          |
|------------------|---------|-----------|--------|---------------|
| GPS (_GPS)       | 1       |           | 0      | 1 6/17/2023   |
| GLONASS (_GLC)   | 1       |           | 0      | 1 6/17/2023   |
| L1 (_L1_)        | 1       |           | 0      | 1 6/17/2023   |
| L2 (_L2_)        | 1       |           | 0      | 1 6/17/2023   |
| Position update  | 200     |           | 0      | 200 6/17/2023 |
| Raw data updat   | 200     |           | 0      | 200 6/17/2023 |
| Memory (Mb) (_   | 511     |           | 0      | 0 ---         |
| Common Tracki    | -1      |           | 0      | 0 ---         |
| 1-PPS Timing Si  | -1      |           | 0      | 0 ---         |
| Event Markers (_ | -1      |           | 0      | 0 ---         |

Figure 5: NetView&Modem \_ Options

## 1.7. Firmware Update

Use NetView&Modem to check the receiver’s firmware version. Information about the firmware version is shown on the main tab once connected. On the right from the receiver picture appears the information about the receiver including receiver model, ID, firmware version.



Base and Rover receivers must be loaded with the same firmware version. To ensure the receiver has the most recent updates, use either the Stable or Latest firmware version, available for download from the JAVAD GNSS website.

To load new firmware using NetView&Modem on a main tab click on the Update Firmware. Select the file with the latest firmware. The firmware will be uploaded automatically, and the receiver will reboot.

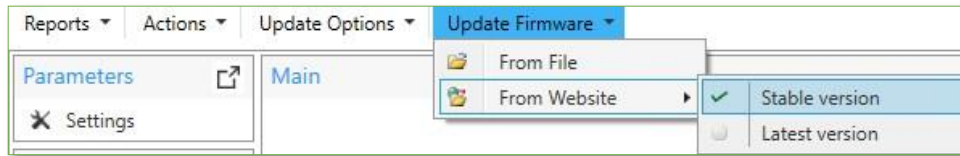

Figure 6: NetView&Modem - Update Firmware

## 1.8. Mounting

The TRIUMPH-1M Plus Receiver can be mounted using the standard 5/8" thread hole on the bottom of the unit.

## 2. Port Connections

### 2.1. USB

The USB cable (P/N: 14-578156-01) supports a connection of any USB 2.0 (high speed) type level cable and above. The USB cable provides a connection from the TRIUMPH-1M Plus to a PC (or any other device with USB connection support). It is possible to establish other connection types using virtual connection ports where physically it will remain the USB cable:

- Serial (COM) port A (for Windows OS devices).
- Serial (COM) port B (for Linux OS devices).
- Ethernet (Ethernet over USB protocol).

For NetView&Modem on a Linux OS, the default connection type is serial (COM – Serial A/B). The physical parameters of the connection types are all via the USB connection.

### 2.2. Bluetooth

The TRIUMPH-1M Plus can establish a Bluetooth connection via Serial Port or PAN Profile. To turn on Bluetooth, use NetView&Modem:

- Pair the TRIUMPH-1M Plus to PC.
- Connect NetView&Modem to TRIUMPH-1M Plus using the assigned Serial (COM) port.
- Go to the Parameters – Ports – Bluetooth section in NetView&Modem.
- At the Mode dropdown, select 'ON'.
- Press OK to reboot the device with Bluetooth on.

The device has two Bluetooth serial ports (A and B). Each port can have modes selected (which port uses the connection) separately or automatically (if both ports are on). To connect external Bluetooth devices to the TRIUMPH-1M Plus, perform the following steps:

- Establish or review Bluetooth identification and password.
- On the external device, find the TRIUMPH-1M Plus ID in listed devices and select it.
- Enter password and connect.

To establish a PAN connection, first connect to the device and use the function 'internet access' on the external device. The TRIUMPH-1M Plus will generate an IP address for the external device.

### 2.3. Wi-Fi

To establish a Wi-Fi connection to the TRIUMPH-1M Plus, perform the following steps:

- Connect the device to a PC using NetView&Modem.
- Go to the Parameters – Connections – WLAN section.
- At the Mode dropdown, select the mode type and confirm to reboot the device (if needed).
- For connecting to the device (server mode), use the corresponding block of parameters with SSID and password. Connect to the unit using an external Wi-Fi device.
- For connecting to the device (client mode), use the corresponding block of parameters with SSID and password. Fill in the SSID and password of an operating WLAN network.

For more details, please see the NetView&Modem User Manual.

## 2.4. Power Management

The TRIUMPH-1M Plus receiver is equipped with an internal (2S3P) battery pack, which is removable at the site whenever required. The battery pack features:

- Power voltage up to 8.3V.
- Internal Fuel Gauge system that prevents any occasions that can damage the battery and device (shortcuts, overheating, etc.).
- Battery lifecycle – about 25 working hours (all systems on).
- Battery charge input – up to 30V.

### 2.4.1. Battery LED

The battery LED shows the status of the internal battery pack.

| Green LED  | Yellow LED      | Red LED    |
|------------|-----------------|------------|
| >30% Power | 15% – 29% Power | <15% Power |

### 2.4.2. Power On / Off

To turn the device on:

- a. Press and hold the PWR button for about 2 sec. (the LED will blink blue; this means the power button is active).
- b. Release the PWR button. The PWR LED will flash yellow (device turning on). Then SAT and POS LEDs will flash red/yellow/green several times (system is loading).
- c. Wait until the PWR, SAT and POS LEDs stop blinking. The PWR will constantly stay with the color from the table above. The rest of LEDs will work according to their status.

Note: If after pressing PWR button the PWR LED flashes several times red and turns off, this means the battery is discharged.

To turn the device off:

- a. Press and hold the PWR button for about 2 sec. (the LED will flash yellow).
- b. The device will turn off by itself.

To maximize battery life, use the JAVAD supplied power cables and charger shipped with the unit.

### 2.4.3. Battery Charging

The supplied power adapter (P/N: 22-570106-01) and power cable (P/N: 14-578125-01) can be plugged into a wall outlet and into the TRIUMPH-1M respectively. A full charging cycle is less than 9.5 hours. The internal battery pack charge status is shown on battery LED:

- Red – Less than 30% charge.
- Yellow – 15-29% charge.
- Green – 30-100% charge.

Note: The internal battery pack cannot be overcharged.

## 2.5. External UHF Radio Connection

To send and receive data using an external UHF radio and a TRIUMPH-1M Plus. To do this, perform the following steps:

- Connect the device to a PC using NetView&Modem (any connection type *except* Bluetooth).
- Configure the external UHF radio by powering it on and connecting it to NetView&Modem.
- Turn Bluetooth on for both devices (if needed).
- Connect the TRIUMPH-1M Plus to the external UHF radio using a Bluetooth SPP connection.
- In the TRIUMPH-1M Plus NetView&Modem connection, go to Parameters – Ports – UHF section and set the mode of the UHF device as needed (depending on base or rover applications).

### 3. Software Interfaces

NetView&Modem software can configure the TRIUMPH-1M Plus for various field applications.

The TRIUMPH-1M Plus can be easily operated in the field using data collection software:

- Field Survey – Window OS devices.
- Javad Mobile Tools – Android OS devices.

These are detailed below.

#### 3.1. NetView&Modem

NetView&Modem can set all the parameters available on the TRIUMPH-1M Plus for various field applications. The device can be connected to the PC using USB, Wi-Fi, or Bluetooth. For more information, see the NetView&Modem User Manual.

#### 3.2. Javad Mobile Tools (JMT)

The TRIUMPH-1M Plus can be easily operated over Bluetooth in the field using the Javad Mobile Tools (JMT) android app.

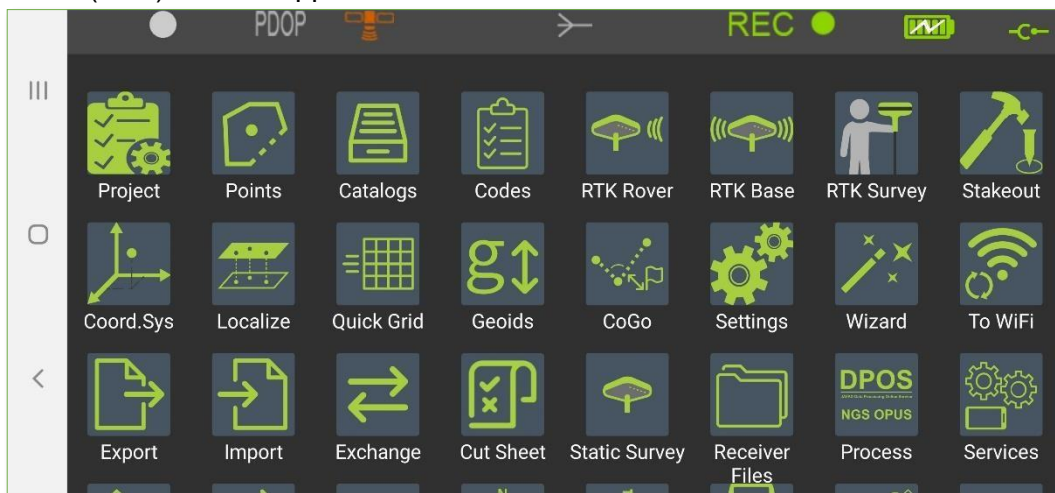

Figure 7: Javad Mobile Tools (JMT)

For more information, see the Javad Mobile Tools User Manual.

#### 3.3. Field Survey

The TRIUMPH-1M Plus can be operated over Bluetooth in the field using the Field Survey Windows OS app.

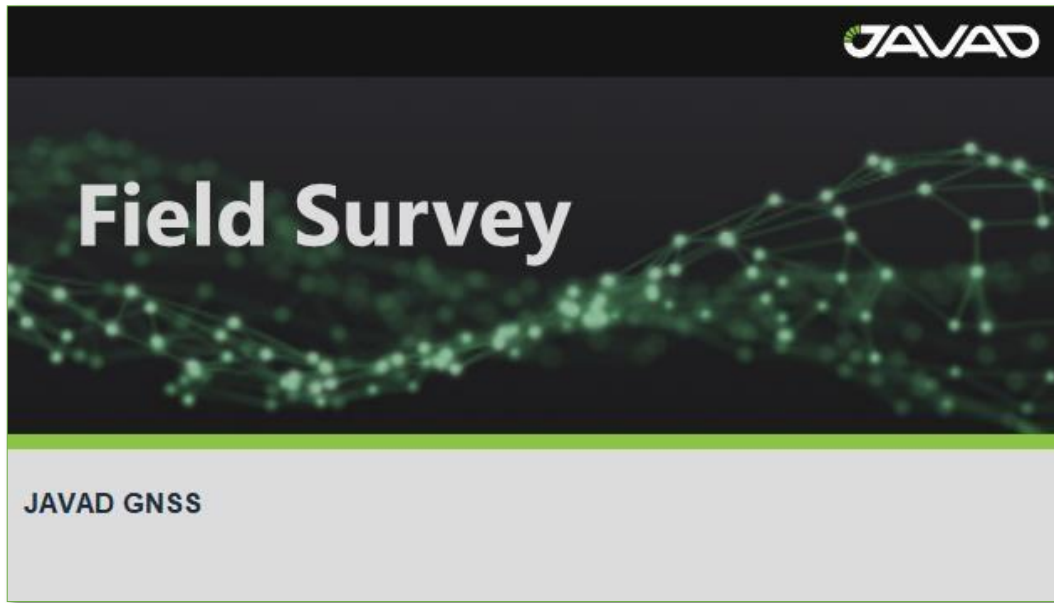

Figure 8: Field Survey

For more information, please see the Field Survey User Manual.

## 4. RTK Configuration

Configuring the TRIUMPH-1M Plus for Base and Rover RTK operation can be performed in NetView&Modem.

### 4.1. RTK Setup for both Base and Rover

The following Base and Rover configurations are the most common for field applications.

| Parameter                      | Base   | Rover          |
|--------------------------------|--|----------------|
| Implicit Message Output Period |  | 15 Seconds     |
| Elevation Mask                 |  | 15 Degrees     |
| File Name Prefix               | Enter a unique ID, such as the last 3 digits of the receiver's serial number. By default, the prefix is 'log'. |                |
| REC (FN) Key Mode              | Starts / Stops the data logging when FN button is pressed  |                |
| Initial Dynamic Mode           | -  | Select Dynamic |

- Connect the receiver and computer, start NetView and establish the connection as described above.
- Click Receiver>Parameters on the left panel.
- In the General tab check antenna status of the parameter Antenna Input to be Internal.
- Open the Log files tab and then TriPad tab and set the following parameters, click Apply.
- Open the Positioning tab and set the Elevation mask (default: 15 Degrees).

To configure a Base station, open the Base tab and set the following parameters:

- Antenna Phase Center Position (APC) – Enter Latitude, Longitude, and Altitude (ellipsoidal) values. This can be manually entered or can be auto filled by the current receiver position using the ‘Get From Receiver’ button.
- Restart the receiver.

To configure a Rover, open the Positioning tab and set the Position Computation Mode:

- PD – Carrier phase differential (RTK) with fixed ambiguities

Open the Rover tab and set the following parameters:

- RTK Position Computation Mode – Select ‘Extrapolation’ for float RTK (kinematic) or Delay for fixed RTK (static). If ‘Extrapolation’ is selected, the rover will extrapolate the base station’s carrier phase measurements when computing the rover’s current RTK position. If ‘Delay’ is selected, the rover will not extrapolate the base station’s carrier phase measurements when computing the rover’s current RTK position. Instead, the RTK engine will compute either a delayed RTK position (for the epoch to which the received correction message corresponds) or the current standalone position (while waiting for new correction messages from the Base).
- Confidence Level for Ambiguity – This governs the process of the RTK engine fixing integer ambiguities. The RTK engine uses the ambiguity fix indicator to determine whether to fix ambiguities or not. Low (95%), Medium (99.5%), and High (99.9%) specify the confidence intervals. The higher the confidence interval, the longer the integer ambiguity search time and higher precision.

For RTK surveys, open the Ports tab and set the parameters according to the table below:

| Parameter    | Base  | Rover                                |
|--------------|---|--------------------------------------|
| Input        | -   | The same correction type as the Base |
| Output       | Select correction type                        | -                                    |
| Period (sec) | Set the period of correction output           | -                                    |
| Baud Rate    | Baud rate for the corresponding receiver port |                                      |
| RTS/CTS      | Enable  |                                      |

Open the Advanced tab – Multipath Reduction and enable ‘Carrier Multipath Reduction’ on Base and Rover for RTK mode.

- Click ‘Apply’ to save the changes to the receiver and close the window. The receiver configuration will remain until changed further or when the NVRAM is cleared (and restore the factory default configuration).

## 5. Setup and Survey

After configuring the receiver(s) for surveying, each receiver needs to be setup up and the receiver’s height measured for the survey to begin. The MinPad provides quick access for logging data, changing receiver modes, and viewing general data logging and satellite information during a survey.

A typical GPS survey system consists of a Base station set up over a known point and a Rover receiver set up to be a mobile data collector. After setting up the Base and Rover receivers, the antenna height must be measured.

Before collecting data, make sure the Base and Rover receivers contain a current almanac and current ephemeris data.

The Base station must be set up, logging, and transmitting data before setting up the Rover receiver. Receiver setup for either post-process or RTK surveys is the same.

## 5.1. Measure Antenna Position

The location of the antenna relative to the point being measured is very important for both surveys in which the elevation of the points is important and in surveys for horizontal location only. Horizontal surveys are often larger in area than can reliably fit on a flat plane, therefore the antenna adjustment must be done in three dimensions and then projected onto a twodimensional plane.

The receiver calculates the coordinates of the antenna's phase center. To determine the coordinates of the station marker, the user must specify the following:

- Measured height of the antenna above the station marker.
- Method of measuring the antenna height.
- Model of the antenna used.

Antennas have two types of measurements:

- Vertical – measured from the marker to the antenna reference point (ARP) located on the bottom of the receiver at the base of the mounting 5/8" thread.
- Slant – measured from the marker to the lower edge of the antenna slant height measure mark (SHMM) located on the side panel of the receiver (green triangle).

The point at which surveying with GNSS measures is called the Antenna Phase Center (APC). This is analogous to the point at which a distance meter measures in a prism. A user must enter the prism offset to compensate for this point not being at the physical surface of the prism. For a GNSS antenna, the offset is entered depending on the type of measurement taken.

To prevent tilting of the receiver, you can use embedded IMU module, which determines deviations from the vertical (relative Earth surface) in real time.

For vertical, the offset is simply added to the measured vertical height to produce a "true" vertical height. For example, surveying poles can be set on specific height. In this case the "true" height will be summary of pole length set and adapter height (if you use one).

For slant height, the vertical height must first be calculated using the radius of the antenna, then the offset can be added.

The offsets are different because of the difference in location between the slant measuring point and the vertical measuring point.

Measure the antenna height to the control point or marker edge, either the slant height or the vertical height.

Record the antenna height, point name, and start time in the field notes.



## 5.2. Collect Data

See the remaining sections in this chapter for more information on collecting data.

- Turn on the receiver.
- Once the receiver has locked on eight or more satellites, the SAT light will turn green.
- The red color of POS LED indicates that the receiver has not solved a position. Four or more satellites provide optimal positioning.
- Once the red POS LED is green, the receiver has a position and surveying can begin; wait for green light before beginning data collection. This ensures that the receiver has the correct date and time and is locked on to enough satellites to ensure good quality data.
- The process of locking on satellites normally takes less than one minute. In a new area, under heavy tree canopy, or after resetting the receiver, it may take several minutes.
- To begin collecting data, press and hold the Record (FN) button (for more than one second and less than five seconds).
- Release the Record button when the REC (recording) LED turns green. This indicates data collection has started. The REC LED blinks each time data is saved to the internal memory.

When finished, press, and hold the Record button until the REC LED light goes out.

To turn off the receiver, press and hold the power button until all lights go out, then release.

## 5.3. Static Survey for Base Stations

Static surveying is the classic survey method, well suited for all kinds of baselines (short, medium, long). At least two receiver antennas, plumbed over survey marks, simultaneously collect raw data at each end of a baseline during a certain period. These two receivers track four or more common satellites, have a common data logging rate (5–30 seconds), and the same elevation mask angles. The length of the observation sessions can vary from a few minutes to several hours. The optimal observation session length depends on the surveyor's experience as well as the following factors:

- The length of the baseline measured.
- The number of satellites in view.
- Satellite geometry (DOP).
- The antenna's location.
- The ionospheric activity level.
- The types of receivers used.
- The accuracy requirements.
- The necessity of resolving carrier phase ambiguities.

Generally, single-frequency receivers are used for baselines whose lengths do not exceed 15 kilometers (9.32 miles). For baselines of 15 kilometers or greater, use dual-frequency receivers.

Dual-frequency receivers have two major benefits. First, dual frequency receivers can estimate and remove almost all ionospheric effect from the code and carrier phase measurements, providing much greater accuracy than single-frequency receivers over long baselines or during

ionospheric storms. Secondly, dual-frequency receivers need far less observation time to reach the desired accuracy requirement.

After the survey is complete, data the receivers collect can be downloaded onto a computer and processed using post-processing software (for example, JAVAD GNSS Justin).

## 5.4. Kinematic Survey for Rover Stations

In a kinematic, stop and go survey, the stationary receiver (Base station) is set up at a known point such as a survey monument, or an unknown point. The receiver continually tracks satellites and logs raw data into its memory. The Rover receiver is set up at an unknown point and collects data in static mode for 2 to 10 minutes. When finished, assign the Rover to kinematic status, and move to the next survey point. At this point, and each subsequent point, the receiver is changed to static mode to collect data. So, while moving, the Rover is in kinematic mode, and while collecting data, the Rover is in static mode.

- Set up the Rover at an unknown point and press the Power button.
- Allow the Rover to collect static data for two to ten minutes. The REC LED will be yellow.
- Check the SAT light for satellites tracked.
- When finished, press the Record (FN) button for less than 1 second to assign the Rover to kinematic.
- Move the Rover to the next location (survey point) and press the Record (FN) button for less than a second to collect the data in static mode for two to ten minutes.
- Repeat the two previous steps until all points have been surveyed. The occupation time for the points depends on the same factors as for the static survey method.

When finished, press the Record (FN) button for one to five seconds to stop logging data. Turn off the Rover if needed. This method of GNSS survey allows the operator to reduce the point occupation time, thus permitting field crews to survey many more points compared to the other methods available.

## 5.5. RTK

With RTK surveying, as with kinematic surveying described above, one receiver serves as the reference station and conducts observations with its antenna affixed to a stationary tripod or some other device. The other receiver functions as a rover and conducts observations (using an antenna) affixed to a mobile pole and moved to observation points.

Unlike post-processed kinematic surveys, RTK surveys utilize a communications link between the Base and Rover. Using a radio modem link, the Base receiver transmits its measurement and location data to the Rover receiver. The Rover, based on the transmitted data and its own observation data, immediately conducts a baseline analysis and outputs the results.

Usually, the receiver will start to output the coordinates of the antenna's phase center along with the solution type within 10–30 seconds. However, UHF radios and GSM phones may take as long as 60 seconds to synchronize. The geodetic coordinates displayed on the Location tab are always computed in WGS84 and have four solution types.

- Standalone – where the receiver computes 3D coordinates in autonomous mode without using differential corrections.

- Code differential – where the Rover receiver computes the current relative coordinate in differential mode using only pseudo ranges.
- RTK float – where the Rover receiver computes the current relative coordinates in differential mode using both pseudo ranges and phases; however, with a float solution, the phase ambiguity is not a fixed integer number, and the “float” estimate is used instead.
- RTK fixed – where the Rover receiver computes current relative coordinates, with ambiguity fixing, in differential mode. The LQ field reflects the status of the received differential messages and contains the following information:
  - Data link quality in percentage.
  - Time (in seconds) elapsed since the last received message.
  - Total number of received correct messages (dependent on the message type received).
  - Total number of received corrupt messages (dependent on the message type received).
  - If the receiver is not (for some reason) receiving differential corrections, or if none of the ports has been configured to receive differential corrections, the LQ field will either be empty, or it will look like this: 100% (999,0000,0000).

## 5.6. File Maintenance

If post-processing the data after completing a measuring, the data in the receiver’s memory will need to be downloaded to a computer. Downloading and deleting files will also prepare the receiver’s memory for the next measuring. Occasionally, the receiver’s NVRAM may need to be cleared to eliminate communication or tracking problems. As project expectations expand, the receiver’s OAF may need to be updated to provide expanded operation and functionality. The receiver requires firmware to properly operate and provide appropriate functionality. As JAVAD GNSS releases firmware updates, loading these updates into the receiver will ensure that the receiver operates at its full potential.

When your measuring finishes, you can download your measuring files to a computer for storage, post-processing, or backup. Also, the TRIUMPH-1M PLUS memory holds a finite number of files and information, so downloading the files to a computer ensures that no files are lost. You should download files as soon as possible after collecting data at the jobsite.

- Connect your receiver and computer. Start NetView. Establish connection between NetView and receiver.
- Click File on the left panel. On the right panel appears the list of files, saved in receiver’s memory. Select the file(s) to download.
- Click the Download button. During the download, status indicators display each file.
- To delete files from your receiver click Delete. Click Yes at the delete files confirmation dialog box. NetView deletes the selected files.

## 6. Mechanical Properties

The TRIUMPH-1M Plus housing is made from lightweight, armored plastic and has a magnesium bottom cover.

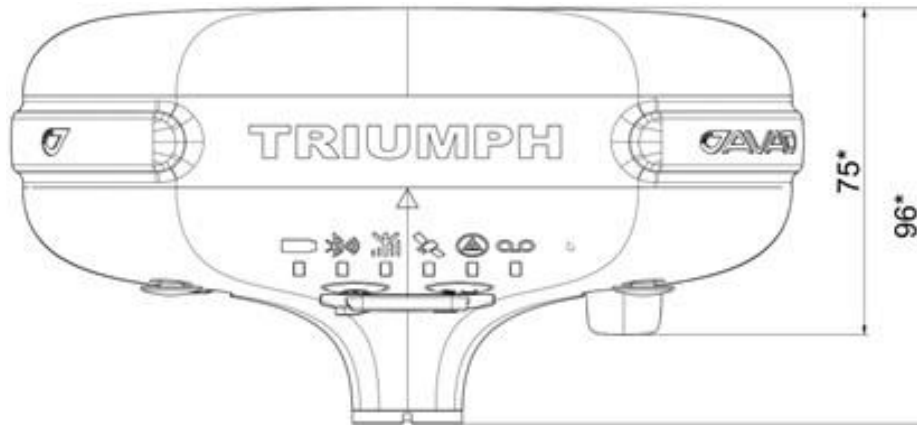

Figure 9: Dimensions

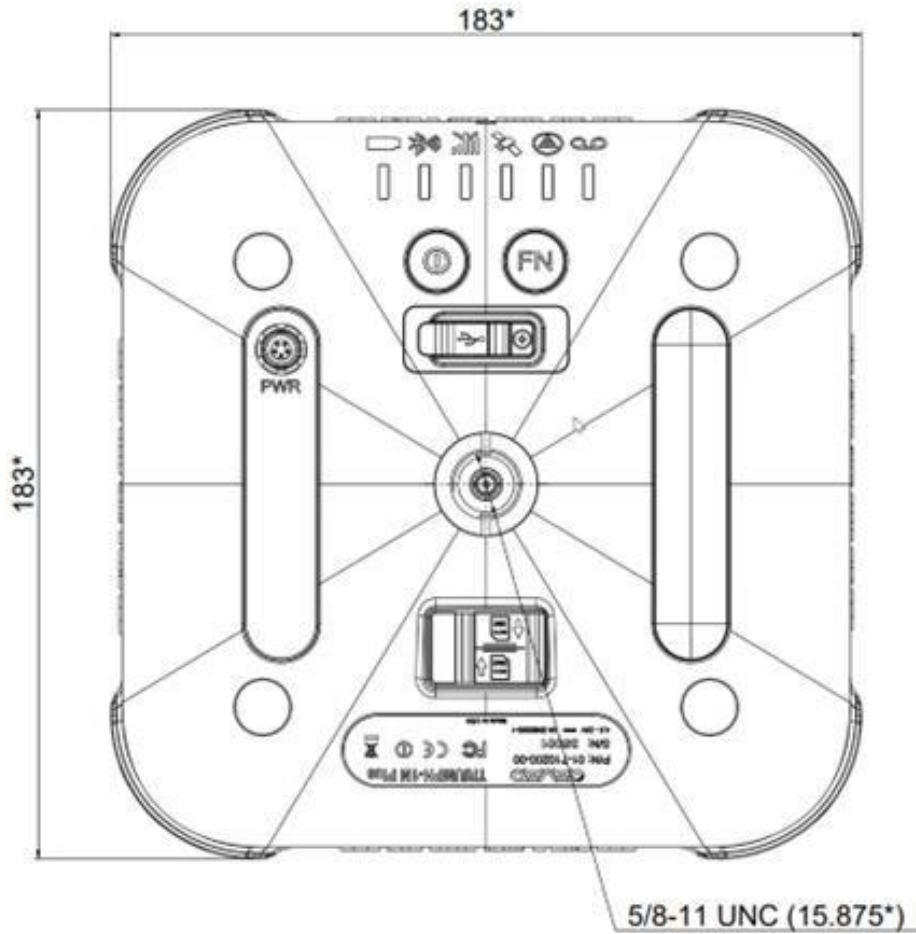

Figure 10: Dimensions

## 7. Troubleshooting

This chapter will help you diagnose and solve some common problems you may encounter with your receiver.

Warning: Do not attempt to repair equipment yourself. Doing so will void your warranty and may damage the hardware.

## 7.1. Check this First

Before contacting JAVAD GNSS support, check the following:

- Check all external receiver connections carefully to ensure correct and secure connections. Double check for worn or defective cables.
- Check all power sources.
- Check that the most current software is downloaded onto the computer and that the most current firmware is loaded into the receiver. Check the JAVAD GNSS website for the latest updates.

Then, try the following:

- Reset the receiver using NetView: Receiver name (on the left panel)4Actions 4Reset.
- Restore default settings using NetView Receiver name (on the left panel)4Actions4Initial parameters.
- Clear the NVRAM.

If the problem persists, see the following sections for other solutions.

For NVRAM cleaning do the following:

- Turn the device off.
- Press and hold Record (FN) button.
- While Record (FN) button is held, press Power button for 1-2 seconds to turn the receiver on.
- Wait until both first and last LEDs turn green.
- In five seconds, both LEDs will blink orange.
- Release Record (FN) button while LEDs are blinking. Note that you have only five seconds while orange-blinking state is on to clean NVRAM.

## 7.2. FAQ

The following are some of the most encountered receiver problems.

### **The receiver port used for connection is not in Command mode.**

- Connect your receiver and computer using a free port and start NetView.
- Change the Input for the port used for connection to “Command”.

### **The receiver does not lock on to satellites for a long period of time.**

- See “Managing Receiver Options” for details on how to check current options.
- Order a new OAF with the desired options activated to enable or extend validity of the corresponding receiver options. Contact your dealer or visit the JAVAD GNSS website for details.
- Refer to the NetView Software Manual for a detailed description of options.

### **The receiver tracks too few satellites.**

- The elevation mask value is too high (above 15 degrees).
- Lower the elevation mask. See “TriPad Configuration” for information on setting the elevation mask.

**The measuring is conducted near obstructions (tree canopy, tall buildings, etc.).**

- Check that the Multipath Reduction boxes have been enabled.
- Connect your receiver to a PC using a free port and start NetView.
- Click enable Multipath reduction and click Apply.
- Move to an area free of obstructions, if applicable.

**The receiver cannot obtain Code Differential and/or RTK solutions.**

- Incorrect Base coordinates entered.
- Specify the correct coordinates for the Base station using NetView or another suitable field data collection software.

**The receiver is not configured as a Base or Rover.**

- If the receiver should function as a Base, ensure it has the proper configuration.
- If the receiver should function as a Rover, ensure it has the proper configuration.
- The corresponding receiver options may be disabled or expired.
- See “Managing Receiver Options” for details on how to check current options.
- Order a new OAF with the desired options activated to enable or extend validity of the corresponding receiver options. Contact your dealer or visit the JAVAD GNSS website for details.
- Refer to the NetView Software Manual for a detailed description of options.

**There are not enough common satellites.**

- To obtain a fixed solution, the Base and Rover should track at least five common satellites.
- Ensure that both the Rover and Base receivers use the same, and updated, almanac.
- Check the elevation masks of the Rover and Base receivers; they should be the same. See “TriPad Configuration” for information on setting the elevation mask.

**A discrepancy exists between the differential standards used at the Base and Rover receivers.**

- Ensure the Base and Rover receivers use the same corrections input/output format.
- Connect your receiver to a PC and start NetView&Modem.
- Click the Ports tab. Use the same input/output format for both receivers.

**Poor satellite geometry (PDOP/GDOP values are too high).**

- Conduct your measuring when PDOP values are low.

**The elevation mask is above 15 degrees.**

- Lower the elevation mask.

**The transmitting and/or receiving antenna may be improperly connected.** • Check that the radio modem’s antenna is securely and properly connected to the antenna connector.

- Check that the radio modem's antenna is undamaged. If damaged, contact your JAVAD GNSS dealer to replace the antenna.

**The specified baud rate is incompatible with the baud rates the receiver supports.**

- The baud rate is the rate at which the receiver transmits differential messages to the receiver and vice versa. Change the baud rate to that which your receiver supports.

**The Base and Rover receivers use different radio link parameters.**

- Configure the Base and Rover radio receivers according to the procedures listed in the applicable section.

**The distance between the Base and Rover is too far.**

- Close the distance between the Base and Rover.
- Use repeaters to increase radio coverage.
- There may be a source of radio interference that disrupts radio communications.
- Change the RF channel (if possible).
- Use a spectrum analyzer to detect the radio characteristics of the interfering signal and change your system's configuration accordingly.
- Remove the source of jamming signal or relocate your radio antennas (if possible).

**The receiver does not start data logging.**

- The memory option is disabled or expired.
- Check that the memory option is enabled. For details, see "Checking an OAF".
- The receiver's memory has no free space.
- Download and/or delete data files to free up space for new files. Use the AFRM feature.

## 8. User Information

### 8.1. Safety Information

Please ensure that you read and understand all safety requirements before using Javad GNSS products.

### 8.2. Usage and Safety

This product is designed to operate in harsh environments typically encountered in surveying applications.

### 8.3. Radio Frequency Exposure

Built-in radio emitters:

The radiated power of the built-in WIFI and Bluetooth modules is well below the RF exposure limits set by the FCC. However, the modules must be used in such a way that the satellite receiver is no closer than 20 cm from the human body. The built-in wireless modules operate in accordance with international regulations and recommendations for the safety of RF emissions.

Javad GNSS ensures that the built-in wireless radio modules are completely safe for the consumer. The level of emitted electromagnetic energy is hundreds of times lower than the

electromagnetic radiation of other wireless devices, such as mobile phones. However, the use of wireless radios may be prohibited in some situations and places, such as on an airplane. If you are not familiar with the current prohibitions, it is recommended that you obtain permission before turning on the wireless radios.

#### 8.4. Warranty

Please contact JAVAD sales managers to find detailed information about company warranty politics.

#### 8.5. Technical Support

If an issue cannot be resolved using product documentation or by your dealer, feel free to contact our Technical Support Team by clicking on 'Send us a Message' on the <https://www.javad.com/contact/> webpage or writing to [support@javad.com](mailto:support@javad.com).